



GMNIAIRE 600V

HEPA Air Filtration Machine



Operation and Maintenance Manual

WARNING

Do not use with combustible or explosive material. Do not expose to water or rain. Connect only to grounded outlet with GFCI device. Disconnect power for cleaning and servicing. This equipment to be operated only by trained personnel.

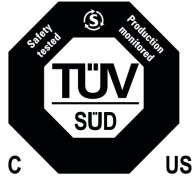

CONFORMS TO UL STD 507
CERTIFIED TO CAN/CSA STD
C22.2 NO. 113-M1984

Safety Warning Instructions:

READ AND SAVE THESE INSTRUCTIONS

This equipment to be operated only by trained personnel.

Do not use with combustible or explosive material.

Do not expose to water or rain.

Connect only to grounded outlet with GFCI device.

Disconnect power for cleaning and servicing.

Do not operate if cord or plug is damaged. Contact a authorized service facility for examination and/or repair.

Do not run cord under carpeting.

Do not cover cord with throw rugs, runners, or similar coverings. Arrange cord away from traffic areas and where it is not a tripping hazard.

Avertissement de sécurité Instructions:

LIRE ET CONSERVER CES INSTRUCTIONS

Cet équipement doit être utilisé que par un personnel formé.

Ne pas utiliser avec des matières combustibles ou explosives.

Ne pas exposer à l'eau ou à la pluie.

Connectez uniquement à une prise mise à la terre avec un dispositif GFCI.

Coupez l'alimentation électrique pour le nettoyage et l'entretien.

Ne pas utiliser si le cordon ou la fiche est endommagé. Contactez un centre de service autorisé pour examen et / ou réparation.

Ne pas passer le cordon sous un tapis. Ne pas couvrir le cordon avec des carpettes, les coureurs, ou revêtements similaires. Éloigner le cordon des endroits passants et où il n'est pas un risque de déclenchement.

The OmniAire 600V is a compact, versatile air scrubber with high airflow and variable speeds. It is used for removal of toxic mold, asbestos and lead dust during renovation and abatement projects, and for purifying air in commercial or factory sites and medical facilities. This popular, light-weight machine is made of strong aircraft grade aluminum housing with smooth surfaces for easy sanitation. It can be used with multiple filter options such as HEPA, activated carbon plus MERV 9 primary/secondary filter. Additional accessories include intake manifold, flex ducting and quick clamps.

Application Examples

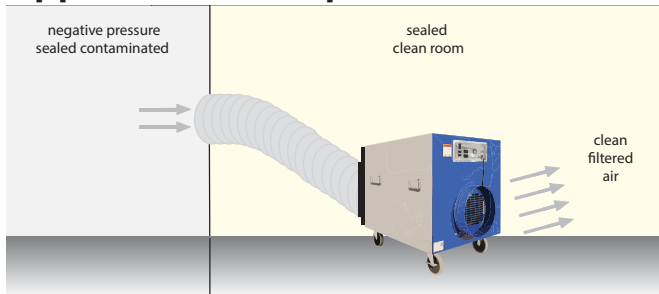

To create **NEGATIVE PRESSURE** inside the containment, more air has to be exhausted out than leaks into the containment. Place the machine inside the containment and hook a flexible duct to the outlet ring of the machine exhausting to outside the containment. (See Above) All of the air being exhausted has been treated by the HEPA filter so no contaminants are being exhausted from the containment.

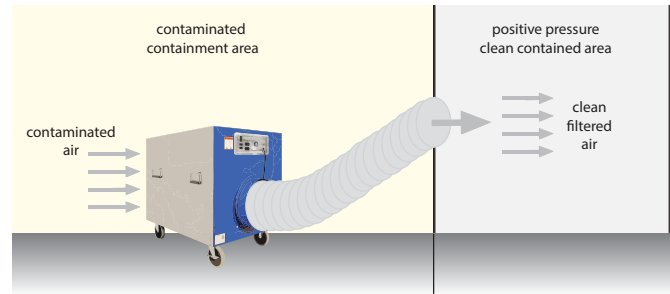

To create **POSITIVE PRESSURE** inside the containment, more air has to be pumped in than leaks out of the containment. Place the machine outside the containment and hook a flexible duct to the outlet ring of the machine ducting the exhaust into the containment. (See Above)

600V Specifications

Airflow: 150-550 CFM

Power Requirements: 115VAC/60 Hz/2.3 Amp

Motor: 0.25 HP with thermal overload

Filtration: HEPA filter 99.97% @ 0.3 μ ; MERV 9 primary/secondary filter

Optional Filtration: OdorGuard 600 activated carbon web filter; HEPA filter 99.99% @ 0.3 μ

Controls: variable speed controller; amber change filter light

Housing: aircraft grade aluminum; silicone sealed before riveting; (2) rubber grip handles; (4) 3" hospital grade locking casters

Exhaust Collar: 8" diameter

Size/Weight with Filters: 14"W x 19"H x 31"L; 58 lbs.

Receiving Instructions

Visually inspect the unit for damage. Remove the primary/secondary filter and ensure that the HEPA filter has not been dislodged during shipping. The HEPA filter should be sitting on the filter guides and the filter tabs that hold the HEPA filter in place should be tight.

If the filter is not seated correctly then remove the filter tabs, reposition the filter, and reinstall the filter tabs before operation to ensure that there is no bypass around the filter. If the filter tabs are loose verifying that the filter is in the correct position and retighten the filter tab nuts.

Operations

For Asbestos and mold abatement, the machine must be operated with a HEPA filter in place. Also, it is recommended to use the primary/secondary filter and replace it frequently to extend the life of the HEPA.

Speed Control

The air flow can be regulated from 150 to 550 cfm by using the VARIABLE speed selector controller and the SPEED CONTROL knob.

Start the Machine

To start the machine in high speed, set the rocker switch HIGH/VARIABLE speed to the HIGH position. In this position the SPEED CONTROL is disabled.

To start the machine in VARIABLE SPEED, set the rocker switch to the VARIABLE SPEED position and rotate the SPEED CONTROL knob clockwise to obtain the desired airflow. As the filters fill with dust, the efficiency of the filters is maintained, but the airflow will decrease, and the vacuum reading will increase. Change the primary/secondary filter frequently to protect the HEPA and to get more air flow. When the amber change filter light comes on, the HEPA filter needs to be replaced to restore airflow. Accessories such as an optional intake manifold can be used on the suction side of the unit providing 12" connection for the flex duct. The discharge side of the unit has a 12" diameter ring for a flex duct.

Maintenance

The blower and motor do not require any maintenance when the machine is operated with the HEPA filter in place.

Pre-Filter Replacement

The primary/secondary filter should be changed when the orange side shows it is loaded with dust. Changing the filter can be done while the machine is running. Ensure that the orange side of the prefilter is facing the HEPA filter.

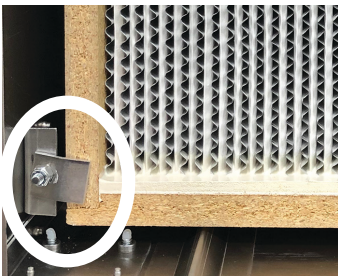

filter tab

HEPA Filter Replacement

During your projects, your HEPA filter purifies the air and gradually becomes loaded with sub-micron particulates. Even when the HEPA filter is fully loaded, the filter is still removing particulates from the air at the rated efficiency yet at a reduced airflow. This will affect the ability of the machine to provide positive or negative pressure within the containment.

To replace the HEPA filter unplug the machine and remove the screen/manifold to remove the prefilter. You will see 4 filter tabs holding the HEPA filter in place (see photo).

These tabs are secured with 1/4-20 Nylock nuts, which require a 7/16" wrench or socket. Remove all 4 filter tab retaining nuts and remove the filter tabs and set aside. Slide the HEPA filter out along the filter guides and remove it from the machine. ALWAYS TREAT THE USED HEPA FILTER AS HAZMAT AND PROCESS IT ACCORDING TO YOUR ESTABLISHED HAZMAT PROCEDURES.

To replace the HEPA filter ensure that the gasket on the HEPA filter faces inwards toward the flange, slide the filter in place along the filter guides and re-install the filter tabs and filter tab securing nuts. The nuts should initially be tightened to where the stud is flush with the end of the nut. This will compress the gasket on the filter approximately 1/2 of the thickness. This allows for the filter to be resealed and tightened later if necessary.

Troubleshooting

Your Omnitec Design machine is designed and engineered to provide years of trouble free service. Occasionally problems occur. Here are some helpful tips and solutions

The machine does not start

1. Check that the unit is plugged in and there is 115VAC available. Select either LOW or HIGH speed to turn the machine on. If the red indicator light comes on, power is coming to the unit from the outlet.
2. Call Omnitec technical support to troubleshoot further.

The machine just hums when turned on

1. Unplug the unit.
2. Remove the HEPA filter and push the blower wheel by hand. If it does not move freely or if you hear a grinding/scrapping noise as you spin it, then the blower wheel is touching the side of the blower housing. This may be due to an impact of some kind and the motor mounts have been bent. Remove the motor/blower assembly and replaced the bent motor mounts.
3. If the blower spins freely, check the capacitor. With the HEPA filter still removed from the machine, insure that the wiring connected to the capacitor is plugged in and not broken. Re-plug the unit into the power outlet keeping the switch in the OFF position. Then push the blower wheel and as it is spinning, turn the speed selector switch to HIGH. If the machine keeps running, the capacitor needs to be replaced.

The machine will run for a few minutes then turn off

1. The machine must have a HEPA filter installed to operate properly. If you are trying to run it without a filter in place, the motor will overheat within a few minutes and the thermal overload will engage and shut it down. Let the motor cool off for 30 minutes, install the filter and try running the machine again.
2. If the filter is in place and the machine still shuts off after a few minutes then the motor is faulty. Replace the motor.

The machine vibrates excessively when running

1. This is an indication that the motor bearings are worn out. If the machine continues running, at this point the vibration will cause the center hub of the blower wheel to separate from the wheel requiring replacement of both the motor and blower. Replace the motor.
2. If the machine does require electrical servicing of the motor or switches the following page contains a wiring diagram to aid in repair or troubleshooting.

Ordering Info

OmniAire 600V

Primary/Secondary Two-Stage Filters (box of 20)

HEPA Filter 99.99%, 0.3 μ (metal frame)

HEPA FILTER 99.97%, 0.3 μ (pb frame)

OdorGuard 600 Carbon Filter

Intake Manifold Kit (Manifold, Clamp & 3' Duct)

ABS Plastic Intake Manifold, 8" Dia.

Quick Clamp, 8"-10" Dia.

Flexible Duct, 8" Dia. x 25' L

Part

OA600V

MFPI313

MFHI2G

MFHI2

OG1212

MFIM8KIT

MFIM8

QCW12

MD8

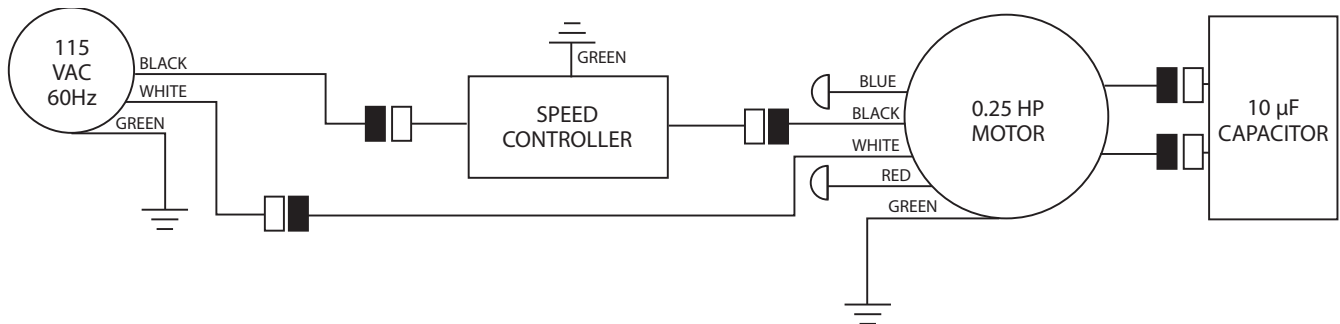

Diagram Legend	
■	Wiring Connector
⌒	Terminated (Capped) Wire
Ⓡ	Red LED Light
ⓐ	Amber LED Light
ⓐ	Green LED Light

	MODEL OA600V	
	Wiring Diagram	
4640 Campus Place, Suite 100 T. 425.290.3922 F. 425.290.3964	DRAWN BY: A. Briceno	REV A
	SCALE Not to Scale	DATE November 9, 2018

Omnitec Design LIMITED WARRANTY

Omnitec Design warrants, for a period of twelve (12) months from the date of purchase, that all Products, component parts and accessories, excluding filters, will be free from defects in material and workmanship under normal use and service.

THE PURCHASER'S SOLE AND EXCLUSIVE REMEDY UNDER THIS WARRANTY IS LIMITED TO THE REPAIR OR REPLACEMENT OF DEFECTIVE PARTS F.O.B., Omnitec Design 4640 Campus Place Ste. 100, Mukilteo, WA 98275
Phone: 425-290-3922

In order to keep this warranty in effect for the aforementioned twelve-month period, the purchaser must (i) promptly, i.e., immediately upon discovery, inform Omnitec Design's customer service of any defects, and (ii) properly use and maintain the Product prior to the discovery of any defect.

This warranty does not cover normal wear and tear or defects caused by (i) improper or negligent handling or unauthorized modifications; (ii) defective or improper premises, chemical, or electrical influences; or (iii) weather or other forces of nature.

In order to provide the best customer service possible, Omnitec Design requests that purchaser completes the enclosed LIMITED WARRANTY REGISTRATION FORM and returns it to Omnitec Design within 30 days of purchase date.

LIMITATIONS OF WARRANTY

THIS WARRANTY IS EXPRESSLY IN LIEU OF ANY AND ALL OTHER WARRANTIES AND OBLIGATIONS OF Omnitec Design OR ITS SUPPLIERS, EXPRESS OR IMPLIED, AND Omnitec Design EXPRESSLY DISCLAIMS ANY WARRANTY OF MERCHANTABILITY OR FITNESS FOR ANY PARTICULAR PURPOSE.

LIMITATION OF REMEDY

Under no circumstances shall Omnitec Design or any supplier of Omnitec Design be liable for any loss or damage, including, but not limited to, loss or damage arising out of the failure of the Products to operate for any period of time, inconvenience, the use of rental or replacement equipment, loss of profits or other economic loss, or general, direct, special, indirect, incidental or consequential damages or property damages.

PRODUCT SUITABILITY

Many states and localities have their own varied codes and regulations governing sales, construction, installation, and/or use of Products for certain purposes. While Omnitec Design attempts to assure that its Products comply with such codes, it cannot guarantee compliance, and cannot be responsible for how the Products are installed or used. Omnitec Design recommends that, before purchasing and using a Product, purchasers review the Product application, and federal, state and local regulations, to be sure that the Products, installation, and use will comply with them.